

Pulsonix TRM Thermal Analysis Option

Thermal Release Management (TRM)

With boards and parts becoming smaller, components and electrical currents heat your board making thermal issues a major threat to the integrity of your product.

TRM is a field simulation software tool and calculates the expected temperature of a printed circuit board in detail based on currents and/or component heating and its cooling to ambient. It runs and displays thermal and electrical analysis (PDN) in an easy-to-use, flexible and powerful toolset.

Import Using the Pulsonix/TRM Interface

Instead of using standard Gerber files and associated Drill files, BOMs etc. Pulsonix uses an integrated interface to collate all the design information required such as all layer structures including layer materials, tracking, copper areas, component data and net data which are all passed into TRM ready for simulation. No complicated data collection or scripts required, this is all taken care of using the Pulsonix TRM interface.

TRM Output options

TRM automatically generates colour images of all variables in all layers and generates a report file. The top and bottom temperature images are the calculated infrared thermograms. The result files can be read into Pulsonix using the TRM interface and overlaid on your design.

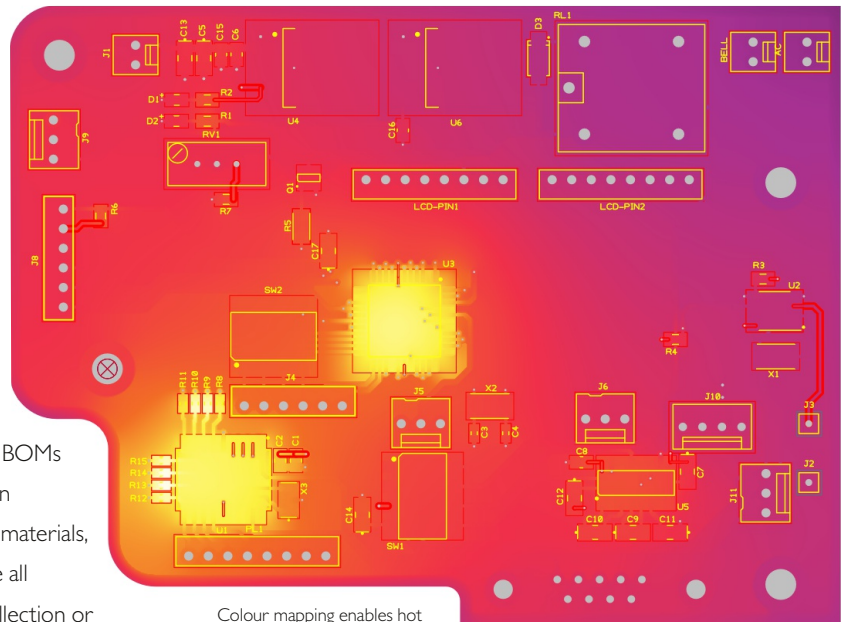

Colour mapping enables hot spots to be easily identified

The Power Of The Integrated Interface

The interface dialog in Pulsonix provides almost everything you need to interface with TRM.

Once the design is prepared, the dialog exports your design data to a file that the TRM import wizard can then import.

The dialog is also used to import the results produced after thermal analysis. Modes for Current, Electrical Conductivity, Heat, No Mode, Temperature, thermal conductivity and Voltage are available. A probe mode enables details analysis to be displayed in a head-up display. Net selection enables specific net results to be displayed; nets of particular interest such as power for example.

Gradient colours and profiles can be defined and managed so that areas of interested can be highlighted.

TRM Bar Interface Feature summary:

- Integrated interface in Pulsonix PCB
- Export of design data to TRM
- Display modes for: Current, Electrical Conductivity, Heat, No Mode, Temperature, thermal conductivity and Voltage
- Probe mode for precise analysis of design
- Net selection enabling specific net results to be displayed
- Gradient Manager for colours and profiles
- Graphical results imported into Pulsonix and overlaid on the design

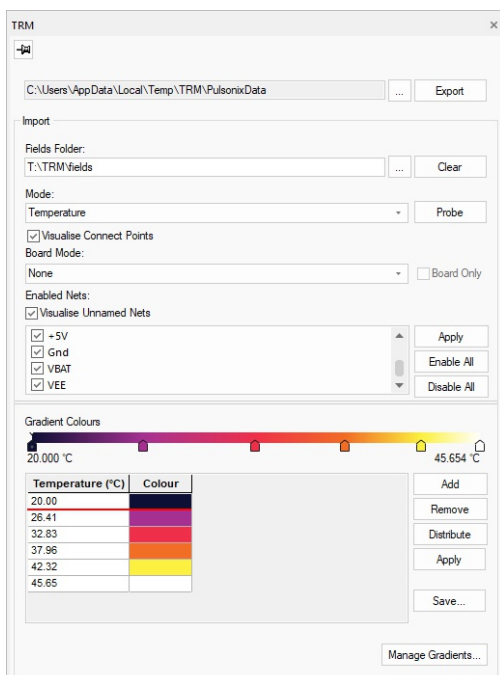

Use the Gradient Manager to define and manage colour profiles

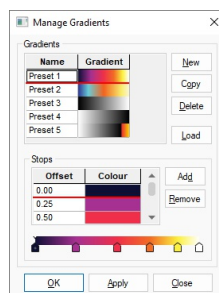

TRM Technology

TRM Product

TRM Accuracy

When input data and laboratory values are well matched, an accuracy of +/-5% can be achieved to the thermal camera.

TRM Physics

The 3D differential versions of potential and heat equations are solved; Currents are DC currents which are fed in and out via plugs or on pads, electricity and component heat diffuses in the panel and is transferred to the ambient air via a flat-rate heat transfer coefficient. This coefficient also contains the proportion of radiation.

Component Models

Detailed component models are not required. Components in TRM have no internal geometry. Average thermal conductivity can be assigned from the database. If the Rjunction-board and Rjunction-case values from a data sheet are used (and trusted), you can enter them for a 2-resistance model.

Fluid Dynamics

No knowledge is required of fluid dynamics because a TRM user is typically a PCB designer or electronics developer. Nevertheless, you can control the influence of housing and fans by selecting the heat exchange coefficient using the software wizard.

Using TRM to calculate time-dependence

TRM can calculate time-dependence; you can either let the power and current have a permanent effect and calculate the heating curve, or the current and power are controlled by a csv file. Virtual thermocouples record the temperature curves.

Substrate Support

As long as the PCB is flat, any technology can be treated: Substrates with improved thermal conductivity, wirelaid technology and stamped parts, press-in technique, ceramics (DCB), dielectric bonded to metal plates (IMS).

Analysis of PCB Installation

As standard, the physical PCB is mounted either vertically in free convection or blown at a certain air velocity. It can also be glued to a finned heat sink, placed on housing domes or the heat can be transferred via a cable via clamping wedges. TRM has selectable options so that each scenario can be analysed.

Component Analysis

The temperature of a component depends on its power dissipation (Watt), its footprint area and the heat spreading capability of copper layer and the FR4 in the PCB. Only in special academic setups it is possible to estimate the temperature from tables or with a calculator. For better results you have to take into account the layout geometry using traces, planes and vias, all of which TRM does.

Refining of TRM Parameters

Using TRM you can perform detailed 3-dimensional temperature calculations. The board model is assembled from the input file generated by Pulsonix. Many more features can be added with the TRM user interface. The resolution in x-y direction typically is of the order of 0.1 mm to 0.2 mm. In addition to heated components electric trace heating (Joule heating) can be treated simultaneously.

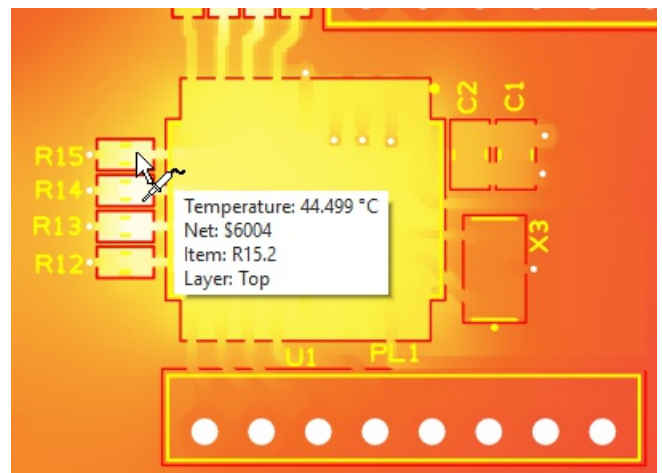

Use the interactive probe in Pulsonix to pinpoint thermal characteristics at a precise location

Component Temperature Influences Function

Voltage drop can substantially depend on the local temperature of the trace (due to T-dependency of electric resistance) either by heating by current or by heating of nearby components. Many other component performance characteristics are also a function of component temperature.

TRM Technology

Current

Current Carrying Capacity is defined as "the maximum electrical current that can be continuously carried by a conductor, without causing an objectionable degradation of electrical or mechanical properties of the product" (IPC-2152). It is easy to oversize trace dimensions: just make it wide and thick. To master the constraints from area, environmental condition and probably time is far beyond guessing and is the realm of detailed TRM simulations.

Electric Current Creating Heat

It is easy to calculate the electric resistance of a trace and to multiply by I^2 . But converting power to temperature depends on heat transfer within the PCB and loss of heat to the ambient. The equilibrium between heat generation and heat loss is represented by the temperature value.

Temperature Simulation and Electric (Joule) heating

Questions arising about temperature are answered by a 3-D simulation with TRM. Trace geometry can show a variety of temperatures depending on the board properties and layout details and other heat sources. This means board configurations, component selection and placement can all be assessed in TRM even before the board is physically manufactured.

TRM also can handle time-dependent currents (e.g. pulses or mission profiles) and calculate temperature transients. These are done using your Layer stack-up and geometry. TRM can also be used to calculate your own ampacity charts meaning you can select the correct conductor for your specific application.

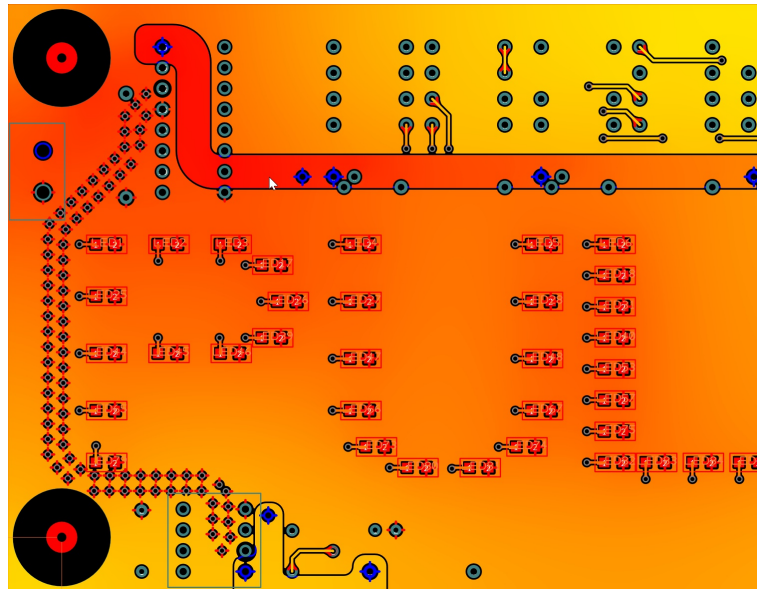

Display critical current maps in Pulsonix

TRM Feature summary:

Analysis Modes:

- Virtual thermographs all layers and prepregs in high resolution
- Trace heating (Ampacity) and component heating
- DC Voltage drop and flow of current in all traces
- Steady state and transient
- Temperature dependent material properties
- Inductance Matrix
- Selective environmental conditions:
 - Air Cooling
 - Conduction cooling and heat sinks
 - Radiation into vacuum
 - Combinations
- Precision by Physics and Geometry

Results:

- 3D exploded view in TRM
- Tables of results
- Efficient computation times even on large designs